



# USER MANUAL

## Ball and Beam Experiment

Set Up and Configuration



© 2011 Quanser Inc., All rights reserved.

Quanser Inc.  
119 Spy Court  
Markham, Ontario  
L3R 5H6  
Canada  
info@quanser.com  
Phone: 1-905-940-3575  
Fax: 1-905-940-3576

Printed in Markham, Ontario.

For more information on the solutions Quanser Inc. offers, please visit the web site at:  
<http://www.quanser.com>

This document and the software described in it are provided subject to a license agreement. Neither the software nor this document may be used or copied except as specified under the terms of that license agreement. All rights are reserved and no part may be reproduced, stored in a retrieval system or transmitted in any form or by any means, electronic, mechanical, photocopying, recording, or otherwise, without the prior written permission of Quanser Inc.

#### Waste Electrical and Electronic Equipment (WEEE)



This symbol indicates that waste products must be disposed of separately from municipal household waste, according to Directive 2002/96/EC of the European Parliament and the Council on waste electrical and electronic equipment (WEEE). All products at the end of their life cycle must be sent to a WEEE collection and recycling center. Proper WEEE disposal reduces the environmental impact and the risk to human health due to potentially hazardous substances used in such equipment. Your cooperation in proper WEEE disposal will contribute to the effective usage of natural resources. For information about the available collection and recycling scheme in a particular country, go to [ni.com/citizenship/weee](http://ni.com/citizenship/weee).

#### 电子信息产品污染控制管理办法（中国 RoHS）



中国客户 National Instruments 符合中国电子信息产品中限制使用某些有害物质命令（RoHS）。  
关于National Instruments 中国 RoHS合规性信息，请登录 [ni.com/environment/rohs\\_china](http://ni.com/environment/rohs_china)  
(For information about China RoHS compliance, go to [ni.com/environment/rohs\\_china](http://ni.com/environment/rohs_china))

#### CE Compliance

This product meets the essential requirements of applicable European Directives as follows:

- 2006/95/EC; Low-Voltage Directive (safety)
- 2004/108/EC; Electromagnetic Compatibility Directive (EMC)

# CONTENTS

<b>1</b>	<b>Presentation</b>	<b>4</b>
1.1	Description	4
1.2	Remote Sensor Option	4
<b>2</b>	<b>Components</b>	<b>5</b>
2.1	Component Nomenclature	5
2.2	Component Description	6
<b>3</b>	<b>Specifications</b>	<b>7</b>
<b>4</b>	<b>System Setup</b>	<b>8</b>
<b>5</b>	<b>Wiring Procedure</b>	<b>10</b>
5.1	Cable Nomenclature	11
5.2	Typical Connections	11
<b>6</b>	<b>Testing and Troubleshooting</b>	<b>14</b>
6.1	SRV02 Motor and Encoder	14
6.2	Ball Position Sensor	14
<b>7</b>	<b>Technical Support</b>	<b>16</b>

# 1 PRESENTATION

## 1.1 Description

The Quanser Ball and Beam module, pictured in Figure 1.1, consists a track on which the metal ball is free to roll. The track is fitted with a linear transducer to measure the position of the ball, i.e., it outputs a voltage signal proportional to the position of the ball. One side of the beam is attached to a lever arm that can be coupled to the load gear of the Quanser SRV02 unit. By controlling the position of the servo, the beam angle can be adjusted to balance the ball to a desired position.



Figure 1.1: Quanser BB01 system

■ **Caution:** This equipment is designed to be used for educational and research purposes and is not intended for use by the general public. The user is responsible to ensure that the equipment will be used by technically qualified personnel only.

## 1.2 Remote Sensor Option

The SRV02 Ball and Beam module can also be accompanied by the Remote Sensor (SS01) shown in Figure 1.2. This enables a master-slave configuration where the ball command is generated by the SS01 instead of through a program.



Figure 1.2: Quanser Remote Sensor (SS01) system

# 2 COMPONENTS

The Ball and Beam components are identified in Section 2.1. Some of those components are then described in Section 2.2.

## 2.1 Component Nomenclature

The components of the Ball and Beam module, i.e., the BB01 device, and the Remote Sensor system, i.e., SS01, are listed in Table 2.1 and labeled in Figure 2.1 and Figure 2.2.

ID	Component	ID	Component
1	SRV02	8	Support base
2	Lever arm	9	Analog ball position sensor connector
3	Coupling screw	10	Support arm screws
4	Steel ball	11	Calibration base
5	BB01 Potentiometer sensor	12	SS01 Potentiometer sensor
6	BB01 Steel rod	13	SS01 Steel rod
7	Support arm	14	Analog remote sensor connector

Table 2.1: Listing of BB01 and SS01 Components

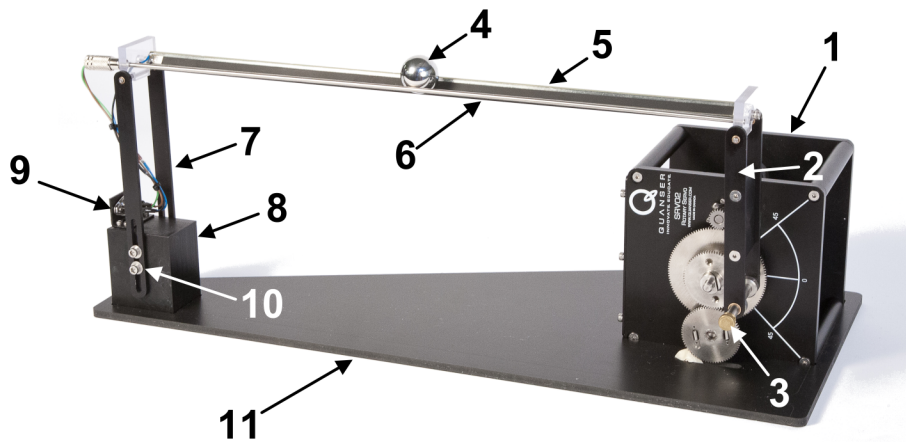

Figure 2.1: Components on Ball and Beam system

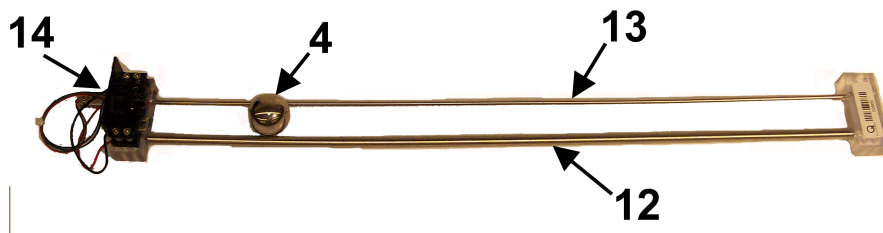

Figure 2.2: Components on Remote Sensor system

## 2.2 Component Description

### 2.2.1 Ball Position Sensor

The track of the BB01 linear transducer module on which the metal ball is free to roll consists of a steel rod in parallel with a nickel-chromium wire-wound resistor forming the track. The resistive wire is the black strip that is stuck on the plastic which is fastened onto the metal frame. The position of the ball is obtained by measuring the voltage at the steel rod. When the ball rolls along the track, it acts as a wiper similar to a potentiometer resulting in the position of the ball.

■ **Caution:** Regular cleaning of the beam is recommended to ensure proper operation of the ball and beam experiment. Clean both the beam and the steel ball using rubbing alcohol.

### 2.2.2 Remote Sensor

Similarly to the BB01, the SS01 has a wiper potentiometer sensor that detects the position of the ball.

# 3 SPECIFICATIONS

Table 3.1 lists and characterizes the main parameters associated with the BB01. See Figure 3.1 for an illustration of the Ball and Beam dimensions and the variables  $\alpha$ ,  $\theta$ , and  $x$  that are associated with the system. Some of the parameters listed in Table 3.1 are used in the mathematical model.

Symbol	Description	Matlab Variable	Value
	Mass of ball beam module		0.65 kg
	Calibration base length		50 cm
	Calibration base depth		22.5 cm
$L_{beam}$	Beam length	L_beam	42.55 cm
	Lever arm length		12.0 cm
$r_{arm}$	Distance between SRV02 output gear shaft and coupled joint	r_arm	2.54 cm
	Support arm length		16.0 cm
$r_b$	Radius of ball	r_ball	1.27 cm
$m_b$	Mass of ball	m_ball	0.064 kg
$K_{bs}$	Ball position sensor sensitivity	K_BS	-4.25 cm/V
$V_{bias}$	Ball position sensor bias power		$\pm 12$ V
$V_{range}$	Ball position sensor measurement range		$\pm 5$ V

Table 3.1: Ball and Beam specifications

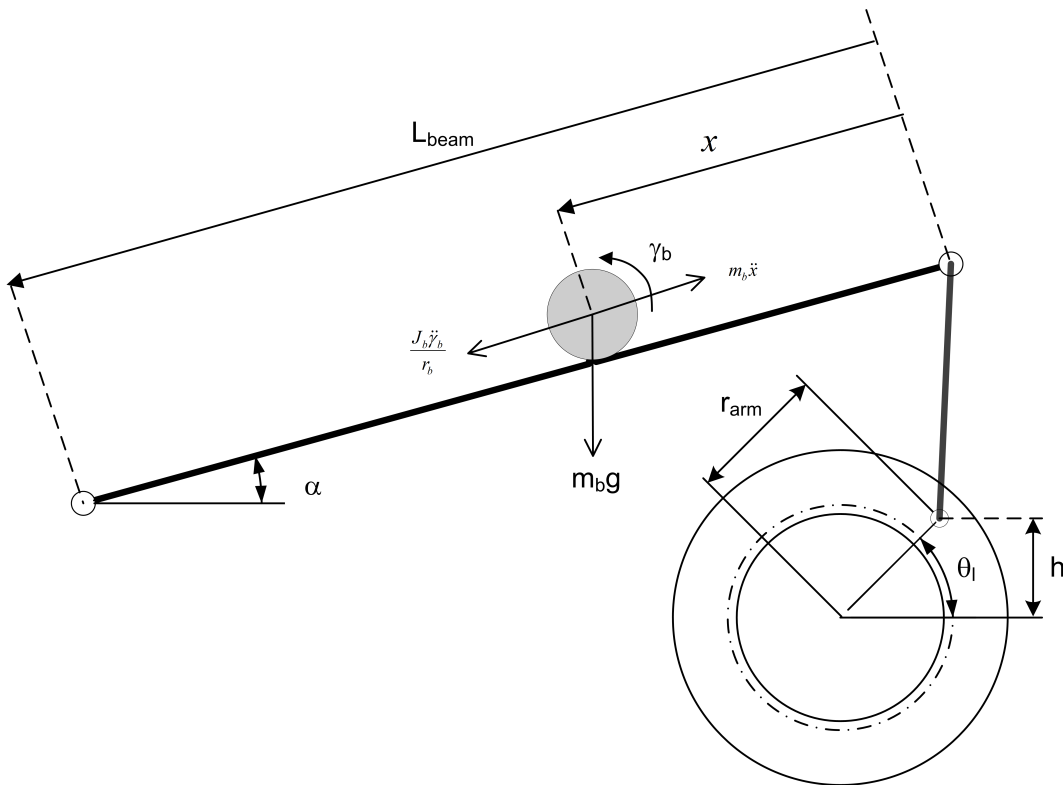

Figure 3.1: Ball and beam lengths and variables

# 4 SYSTEM SETUP

This section describes how to setup the Quanser Ball and Beam (BB01) system for experimental use.

■ **Caution:** If the equipment is used in a manner not specified by the manufacturer, the protection provided by the equipment may be impaired.

■ **Caution:** Exposed moving parts.

Follow this procedure to setup the Ball and Beam system:

1. Before beginning, ensure the SRV02 is setup in the high-gear configuration as detailed in SRV02 User Manual [2].
2. Lay the calibration base, component #11 in Figure 2.1, flat on a table surface.
3. As pictured in Figure 4.1, place the SRV02 on its side such that the potentiometer gear fits into the cut-out section of the calibration base.



Figure 4.1: Place SRV02 in calibration base

4. Place the support column of the Ball and Beam into the cut-out section of the calibration base, as shown in Figure 4.2.



Figure 4.2: Place BB01 support column in calibration base

5. Tighten the coupling screw into the screw hole of the large 120-tooth load gear as depicted in Figure 4.3.



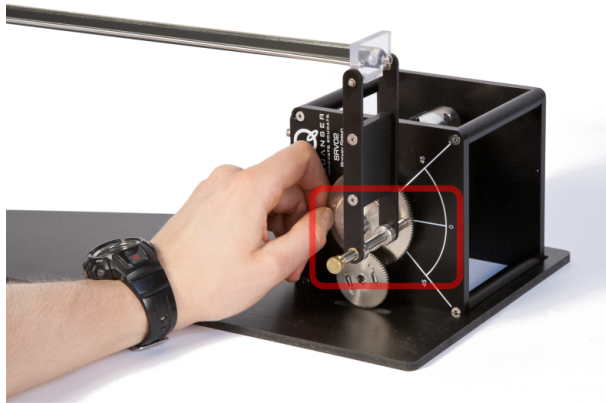

Figure 4.3: Attach BB01 to SRV02 and rotate the gear to 0 degrees.

6. As illustrated in Figure 4.3, manually rotate the servo load gear to the 0 degree position. The coupling screw should be aligned with the 0 degree position on the servo.
7. See Figure 4.4. While holding the load gear at 0 degrees, place the ball in the center of the beam and vary the height of the support arm such that the beam is approximately horizontal and the ball does not move.



Figure 4.4: Adjust height of support column until ball is balanced at middle of beam

8. Tighten the 4x screws on the support arm, as illustrated in Figure 4.5, to finalize the calibration of the Ball and Beam.

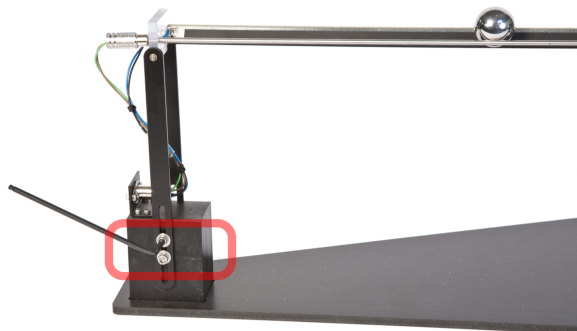

Figure 4.5: Tighten 4x screws on column to fix the height

# 5 WIRING PROCEDURE

The following is a listing of the hardware components used in this experiment:

- **Power Amplifier:** Quanser VoltPAQ-X1, or equivalent.
- **Data Acquisition Board:** Quanser QPID, QPIDe, Q8-USB, Q2-USB, or equivalent.
- **Rotary Servo Plant:** Quanser SRV02-ET, SRV02-ETS, or equivalent.
- **Ball and Beam:** Quanser BB01 Module
- **Remote Sensor:** Quanser SS01 Module

See the corresponding documentation for more information on these components. The cables supplied with the SRV02 are described in Section 5.1 and the procedure to connect the above components is given in Section 5.2.

■ **Caution:** When using the Quanser VoltPAQ-X1 power amplifier, **make sure you set the Gain to 1!**

## 5.1 Cable Nomenclature

The cables used to connect the Quanser SRV02 system with a power amplifier and data-acquisition device is shown in Table 5.1. Depending on your configuration, not all these cables may be necessary.





Cable	Type	Description
 (a) RCA Cable	2xRCA to 2xRCA	This cable connects an analog output channel on the data acquisition board to the power amplifier for amplification.
 (b) Motor Cable	4-pin-DIN to 6-pin-DIN	This cable connects the output of the power amplifier to the dc motor on the servo.
 (c) Encoder Cable	5-pin-stereo-DIN to 5-pin-stereo-DIN	This cable carries the encoder signals between an encoder connector and the data acquisition board (to the encoder counter). Namely, these signals are: +5 VDC power supply, ground, channel A, and channel B
 (d) Analog Cable	6-pin-mini-DIN to 6-pin-mini-DIN	This cable carries analog signals (e.g., from a potentiometer) to the amplifier, where the signals can be either monitored and/or used by a controller. The cable also carries a $\pm 12$ VDC line from the amplifier in order to power a sensor and/or signal conditioning circuitry.
 (e) 5-pin-DIN to 4xRCA	5-pin-DIN to 4xRCA	This cable carries the analog signals, unchanged, from the amplifier to the Analog-To-Digital input channels on the data acquisition terminal board.

Table 5.1: Cables used to connect SRV02 to amplifier and DAQ device

## 5.2 Typical Connections

This section describes the typical connections used to connect the SRV02 plant to a data-acquisition board and a single-channel power amplifier. The connections are given in Table 5.2 and illustrated in Figure 5.1. The detailed wiring procedure is given below as well.

**Note:** The data acquisition (DAQ) device used in Figure 5.1 is representative for any DAQ device.

Cable #	From	To	Signal
1	Terminal Board: DAC #0	Amplifier <i>Amplifier Command</i> connector	Connects control signal from Analog Output #0 on DAQ device to the power amplifier.
2	Amplifier: <i>To Load</i> connector	SRV02 <i>Motor</i> connector	Power leads to the SRV02 dc motor.
3	Terminal Board: Encoder Input #0	SRV02 <i>Encoder</i> connector	Encoder load shaft angle measurement.
4	Amplifier: <i>To ADC</i> connector	Terminal Board: <ul style="list-style-type: none"> <li>S3 to ADC #0</li> <li>S4 to ADC #1</li> </ul>	Connects BB01 and Remote Sensor (SS01) ball position measurement to analog input channels #0 and #1 on the DAQ device.
5	Amplifier S3 connector	BB01 Ball Position Sensor connector	Ball and Beam (BB01) ball position measurement.
6	Amplifier S4 connector	SS01 Ball Position Sensor connector	Remote Sensor (SS01) ball position measurement.

Table 5.2: BB01 Wiring

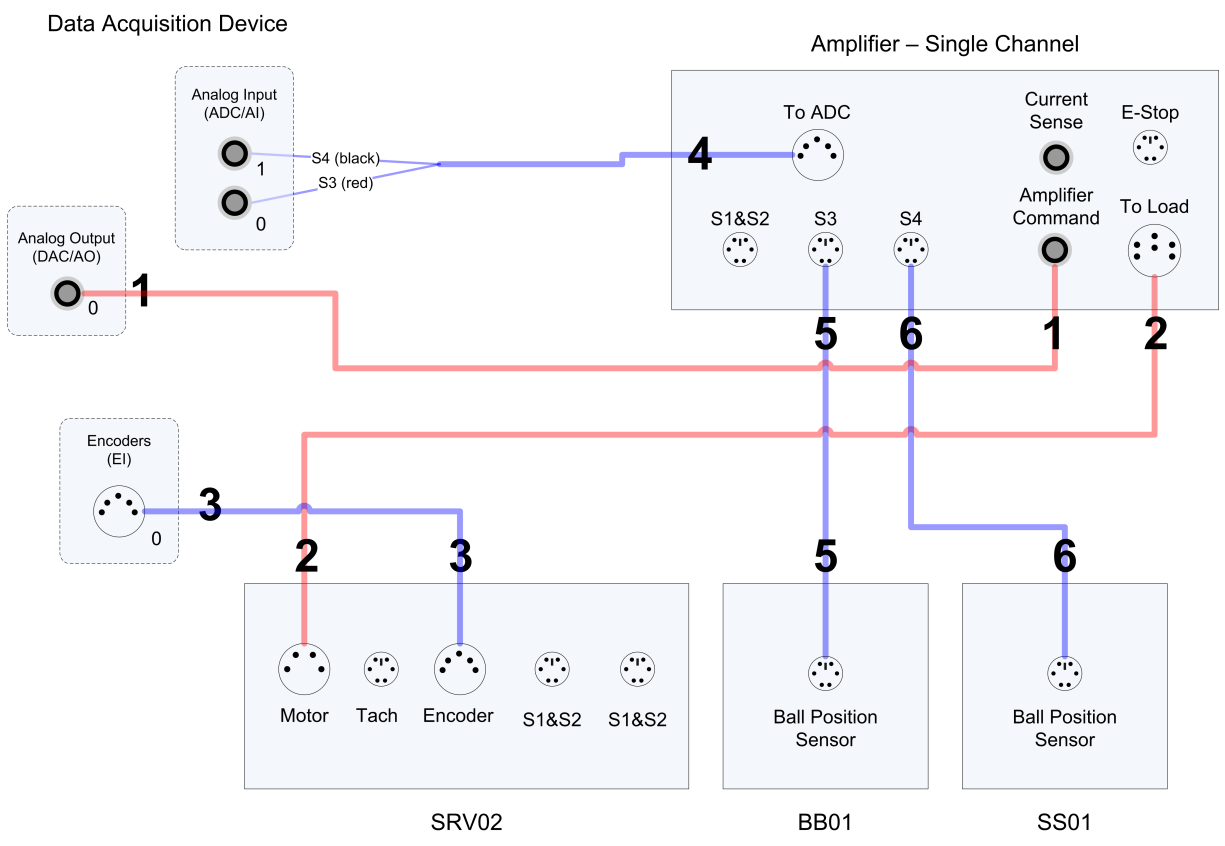

Figure 5.1: BB01 connections using generic DAQ with a single-channel amplifier

Follow these steps to connect the SRV02 system:

1. Make sure that your data-acquisition device is installed and is operational. For example, see [3] if the Quanser Q2-USB will be used.

2. Make sure everything is powered off before making any of these connections. This includes turning off your PC and the amplifier.
3. Connect one end of the 2xRCA to 2xRCA cable from the Analog Output Channel #0 on the terminal board to the *Amplifier Command* connector on the amplifier, i.e. use both white or both red RCA connectors. See cable #1 shown in Figure 5.1. This carries the attenuated motor voltage control signal,  $V_m/K_a$ , where  $K_a$  is the amplifier gain.
4. Connect the 4-pin-stereo-DIN to 6-pin-stereo-DIN cable from *To Load* connector on the amplifier to the *Motor* connector on the SRV02. See connection #2 shown in Figure 5.1. The cable transmits the amplified voltage that is applied to the SRV02 motor and is denoted  $V_m$ .
5. Connect the 5-pin-stereo-DIN to 5-pin-stereo-DIN cable from the *Encoder* connector on the SRV02 panel to Encoder Input # 0 on the terminal board, as depicted by connection #3 in Figure 5.1. This carries the load shaft angle measurement and is denoted by the variable  $\theta_l$ .  
**Note:** In this setup, it is assumed the SRV02 encoder is used for position feedback (i.e., not using the potentiometer).  
**■ Caution:** Any encoder should be directly connected to the data-acquisition terminal board (or equivalent) using a standard 5-pin DIN cable. **DO NOT connect the encoder cable to the amplifier!**
6. Connect the *To ADC* socket on the amplifier to Analog Inputs #0-1 on the terminal board using the 5-pin-DIN to 4xRCA cable. Connect the red (S3) RCA connector to Analog Input Channel #0 and the black (S4) RCA connector to Analog Input Channel #1. **Note:** The RCA cables may not be labeled S1, S2, S3, and S4. In that case, use the colour convention yellow (S1), white (S2), red (S3), black (S4).
7. Connect the *Ball Position Sensor* connector from the BB01 to the S3 socket on the amplifier using the 6-pin-mini-DIN to 6-pin-mini-DIN cable. See connection #5 in Figure 5.1. This carries the the measured ball position from the beam potentiometer and is denoted by variable  $x$ .
8. If the SS01 remote sensor module (shown in Figure 2.2) is used, then connect *Remote Ball Position Sensor* connector from the SS01 remote sensor module to the S4 socket on the amplifier using the 6-pin-mini-DIN to 6-pin-mini-DIN cable. See connection #6 in Figure 5.1. This measures the ball position on the remote sensor and is denoted by  $x_d$ .

# 6 TESTING AND TROUBLESHOOTING

This section describes some functional tests to determine if the Ball and Beam system is operating properly. It is assumed that the system is connected as described in the Section 5, above. To carry out these tests, it is preferable if the user uses a software such as **QUARC®** or **LabVIEW™** to read sensor measurements and output voltages to the motor. See Reference [1] to learn how to interface the SRV02 with QUARC. Alternatively, these tests can be performed with a signal generator and an oscilloscope.

## 6.1 SRV02 Motor and Encoder

See [2] for information on testing and troubleshooting the SRV02 separately.

## 6.2 Ball Position Sensor

### 6.2.1 Testing

Test the ball position sensor from the BB01 or SS01 with the following procedure:

1. Measure analog input channel #2 to test the BB01 sensor or analog input channel #3 to test the SS01 sensor (unless the sensors are connected on a different channels).
2. A typical signal response of the ball position sensor is illustrated in Figure 6.1. For the BB01, the ball position sensor should output a voltage of about 4.5 V when it is closest to the SRV02. As the ball is rolled away from the SRV02 the measured voltage signal should be decreasing down to approximately -4.5 V when the ball reaches the other end of the beam.  
**■ Caution:** Sometimes when the ball is sitting at the very end of the beam it may not be in contact with the sensor. In this case the reading will initially be 0 V but when the ball begins moving the sensor signal will jump up to about 4.5 V and then begin decreasing.
3. Beside the ends of the beam, the signal should have no discontinuities and little noise. Similarly for the SS01 sensor, the voltage signal should decreasing from approximately 4.5 V to -4.5 V as the ball travels towards the end of the beam with the analog connector.

### 6.2.2 Troubleshooting

Follow the steps below if the potentiometer is not measuring correctly:

- Verify that the power amplifier is functional. For example when using the Quanser VoltPAQ device, is the green LED lit? Recall the analog sensor signal go through the amplifier before going to the data-acquisition device (except when using the Q3 ControlPAQ). Therefore the amplifier needs to be turned on to read the potentiometer.
- Check that the data-acquisition board is functional, e.g. ensure it is properly connected, that the fuse is not burnt.
- Measure the voltage across the potentiometer. Ensure the potentiometer is powered with a  $\pm 12$  V at the 6-pin-mini DIN connector on the BB01, component #10 in Figure 2.1, or on the SS01, component #14 in Figure 2.2. The two bottom pins of the DIN connector are GND pins and the leftmost pin, i.e. where the green cable is connected to, outputs the voltage of the ball.

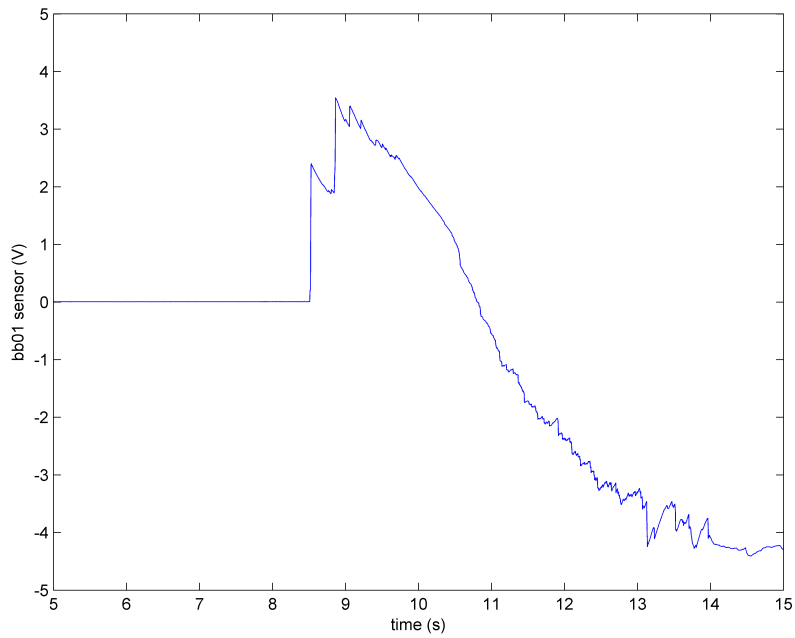

Figure 6.1: Typical voltage signal measured by the BB01 ball position sensor

- Using a voltmeter, connect one probe to the middle-left pin and the other to the bottom GND pins. The voltage should vary between about  $\pm 4.5$  V as the ball position is changed. Please see Section 7 for information on contacting Quanser for technical support.

## 7 TECHNICAL SUPPORT

To obtain support from Quanser, go to <http://www.quanser.com/> and click on the Tech Support link. Fill in the form with all the requested software and hardware information as well as a description of the problem encountered. Also, make sure your e-mail address and telephone number are included. Submit the form and a technical support person will contact you.



# REFERENCES

- [1] Quanser Inc. *SRV02 QUARC Integration*, 2008.
- [2] Quanser Inc. *SRV02 User Manual*, 2009.
- [3] Quanser Inc. *Q2-USB Data-Acquisition System User's Guide*, 2010.

## Over ten rotary experiments for teaching fundamental and advanced controls concepts



Quanser's rotary collection allows you to create experiments of varying complexity – from basic to advanced. Your lab starts with the Rotary Servo Base Unit and is designed to help engineering educators reach a new level of efficiency and effectiveness in teaching controls in virtually every engineering discipline including electrical, computer, mechanical, aerospace, civil, robotics and mechatronics. For more information please contact [info@quanser.com](mailto:info@quanser.com).

©2012 Quanser Inc. All rights reserved.



**QUANSER**  
INNOVATE. EDUCATE.

[INFO@QUANSER.COM](mailto:INFO@QUANSER.COM)

+1-905-940-3575

[QUANSER.COM](http://QUANSER.COM)

Solutions for teaching and research. Made in Canada.